



**SAPIM**  
spokes and nipples



● ● ● [www.sapim.eu](http://www.sapim.eu)



**SAPIM**

**SPOKES  
AND NIPPLES**

®





**Founded in 1918, SAPIM has been producing spokes and nipples of the highest quality for over 90 years. From the beginning, maintaining a close relationship with customers has always been of the greatest importance. By listening to the needs and wishes of our customers, whether professional or amateur, our products are tailored to meet their requirements. Flexibility in the production process means new innovations are quickly brought into the program. At SAPIM, your safety is our main concern. Only materials of the highest possible standard are used. Thanks to our ISO 9001 certification standard and to our STTS (SAPIM Total Traceability System), SAPIM is able to guarantee that every spoke and nipple is meticulously monitored and checked throughout the entire production process, bringing only the best to our customers.**

“SAPIM's strength comes from the expertise and commitment of its employees, some have been with the company for over 30 years! They bring a passion to their work, producing the best possible spokes and nipples for our customers. As a long established company, built on solid foundations, SAPIM is dynamic and innovative, but reliable. We actively support professional and amateur bicycle racing in its many forms and are constantly evaluating how our products perform under the most extreme pressures. For , SAPIM has been among the leaders in spoke and nipple production and our continued success is due to rigorous levels of quality control, innovative products, and solid pricing structure.”

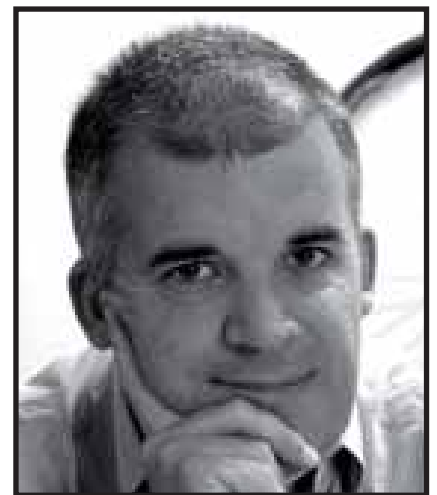

*Axel Moorkens, CEO Sapim*



At a lot of international events SAPIM offers race service to their customers. Our target is to help the consumers, team riders and team mechanics with our knowledge of wheel building. Bringing together good wheel building with our superior spokes offers the customer best possible wheels.

Annually many Protour teams and many World cup Mountain biker decide to ride with our spokes.

Also wheel building courses are held by SAPIM. Only good wheel building shows all positive aspects of our spokes and nipples in a wheel. A checklist is offered as well.



## AERO SPOKE

SAPIM aero spokes not only give an aerodynamic edge, they also make wheels lighter and stronger. As light as titanium spokes, CX-Ray still receive the best results in fatigue testing of any spoke. No doubt why CX-Ray are used by top bike racers and triathletes around the world. Even downhillers use them, recognising their strength and flexibility. Special alloy treatment and sophisticated production make all this possible. Aero spokes are produced from the best suited stainless steel for spokes: high-tensile, fatigue-resistant 18/8 stainless steel conforming to SAPIM quality standard specifications. The CX-Ray fits easily into all standard hubs.



Cx/Cx-Ray Key

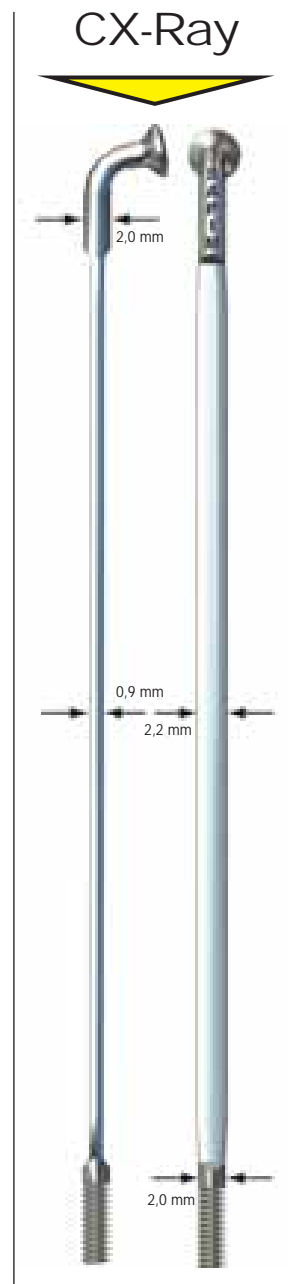

INOX 18/8

Ø 2,0 - ~~2,2~~ 0,9 - 2,0 mm  
Length: 146 - 310 mm

Usage	Race, Triathlon, MTB, Downhill
Weight	278 g (64 x 260 mm)
Fatigue test wheel revolutions	3.500.000
Strength on middle section	1600 N/mm <sup>2</sup>
Packaging quantities	20, 100, 500
Nipples	14 mm silver aluminium Polyax

Sapim spokes and nipples are produced with the most exact thread-tolerance for durability and the highest level of quality. The Sapim Total Traceability System (STTS) guarantees perfect quality control. All Sapim components conform to DIN 79.100.



## BUTTED SPOKES

SAPIM butted spokes have two major benefits: less weight and more strength! Technological advances using cold forging (SAPIM Forging Technology) 'stretch' the spoke, retaining the linear molecular structure of the material, thereby increasing the spoke strength at the middle by at least 48%. As an added bonus, the thin middle section of the light Laser and Race spokes also provides better shock absorption. The Strong, with its extra material in the bend, fits more tightly into the hub hole making it ideally suited for disc brakes, as well as for tandems and other heavy duty applications.

	Force	Laser	Race	Strong
	INOX 18/8 Ø 2,2 - 1,8 - 2,0 mm Length: 252 - 268 mm	INOX 18/8 Ø 2,0 - 1,5 - 2,0 mm Length: 145 - 309 mm	INOX 18/8 Ø 2,0 - 1,8 - 2,0 mm Length: 146 - 310 mm	INOX 18/8 Ø 2,3 - 2,0 mm Length: 180 - 310 mm
Usage	Disc-Brake, Heavy Duty, Long distance travel	Race, Triathlon, Cross Country	Race, Triathlon, MTB, Trekking	Downhill, Trekking, City, MTB
Weight	368 g	279 g (64 x 260 mm)	360 g (64 x 260 mm)	430 g (64 x 260 mm)
Fatigue test wheel revolutions	2 Mio	1.250.000	980.000	1.600.000
Strength on middle section	1350 N/mm <sup>2</sup>	1500 N/mm <sup>2</sup>	1350 N/mm <sup>2</sup>	1400 N/mm <sup>2</sup>
Packaging quantities	100, 500	50, 500	100, 500	100, 500
Nipples	12 mm brass Polyax	12 mm brass Polyax	12 mm brass Polyax	12 mm brass Polyax

Sapim spokes and nipples are produced with the most exact thread-tolerance for durability and the highest level of quality. The Sapim Total Traceability System (STTS) guarantees perfect quality control. All Sapim components conform to DIN 79.100.



## BASIC SPOKES

Intended for everyday use, these spokes are produced using top quality materials. Made from high-tensile, fatigue-resistant stainless steel conforming to SAPIM quality standard specifications, the Leader forms the basis for all other spokes. It is also available in black without losing any of the properties found in non-coloured versions.

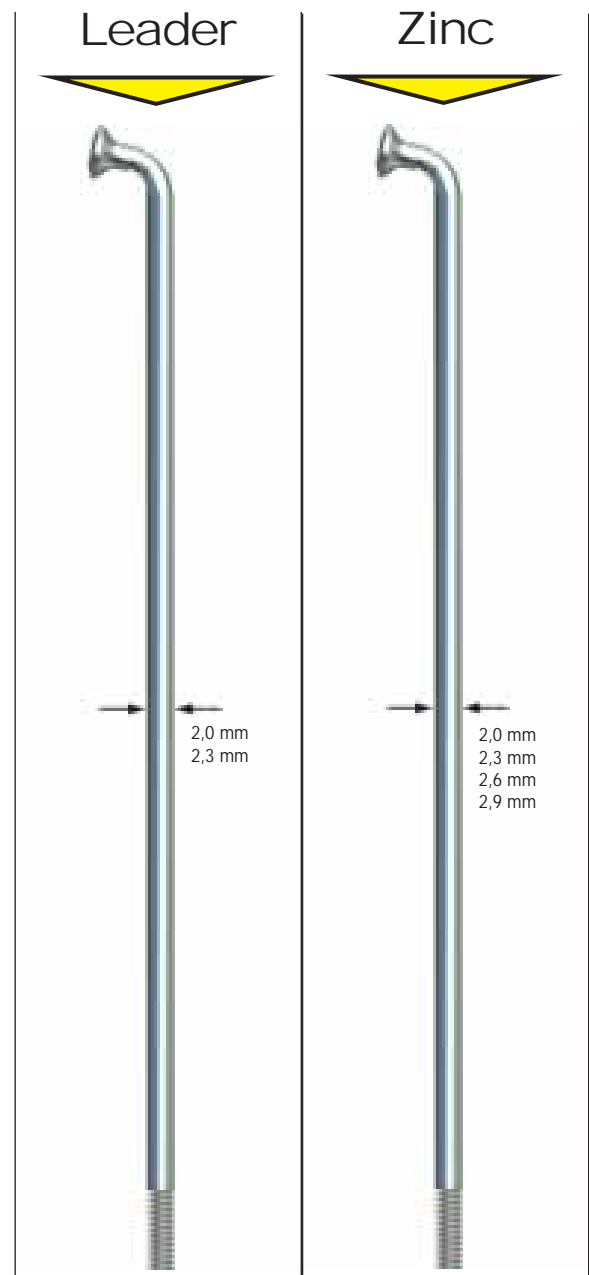

**Standard: Ø 2,0 / 2,3 mm**  
**Others: Ø 2,6 / 2,9 mm**  
**Length: 130 - 310 mm**

**Standard: Ø 2,0 mm**  
**Others: Ø 2,3 / 2,6 / 2,9 mm**  
**Length: 130 - 310 mm**

Usage	City, Trekking, MTB, Tandem,	City, Trekking
Weight	421 g (64 x 260 mm)	424 g (64 x 260 mm)
Fatigue test wheel revolutions	870.000	700.000
Strength on middle section	1080-1180 N/mm <sup>2</sup>	950-1050 N/mm <sup>2</sup>
Packaging quantities	100, 500	144, 500
Nipples	12 mm Polyax brass	12 mm standard brass

Sapim spokes and nipples are produced with the most exact thread-tolerance for durability and the highest level of quality. The Sapim Total Traceability System (STTS) guarantees perfect quality control. All Sapim components conform to DIN 79.100.

# NIPPLES

## Original Sapim Polyax Nipples

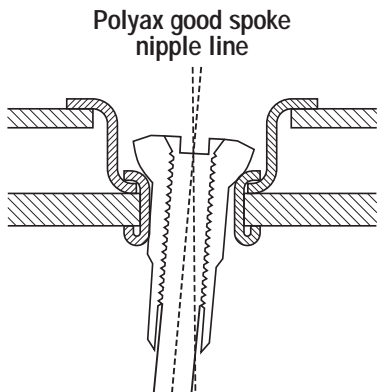

Polyax good spoke nipple line

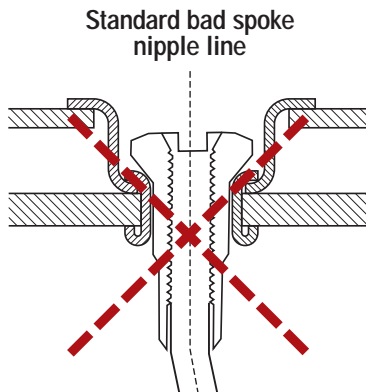

Standard bad spoke nipple line

Silver colour nickel-plated brass: 12,14,16mm  
 Option: black  
 Packaging quantities: 20, 50, 100, 144, 500

## Inverted Nipple



- Available in brass 8,5, 10 and 12mm for 14G and 12mm for 13G thread.  
 - Available in aluminium 12mm length for 14G thread.

## S.I.L.S. Polyax Sapim Integrated Locking System



Sapim's revolutionary nipple

### The Self-Securing Nipple

- no more early loosening
- no time wasted gluing screw threads
- environmentally friendly
- sticking qualities not affected by re-centring wheel
- increases spoke life and overall wheel safety
- also suitable for machine wheel-building

## Hexagonal Head

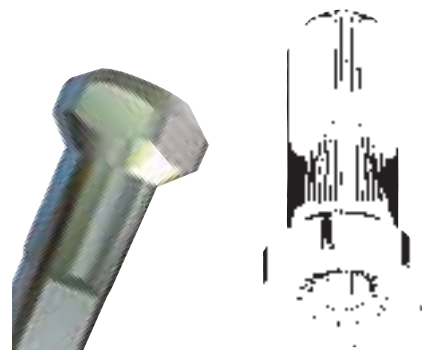

Brass: 12,14,16  
 Hexagonal head nipples for "V" section rims and special rim profiles.

## Reduction Nipple

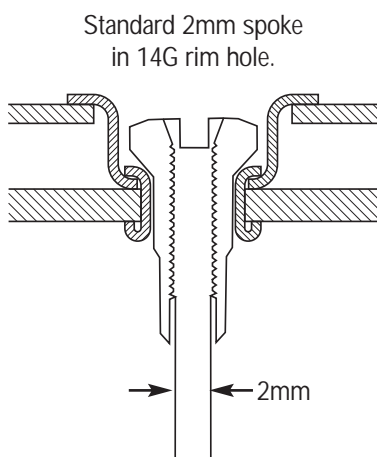

Standard 2mm spoke in 14G rim hole.

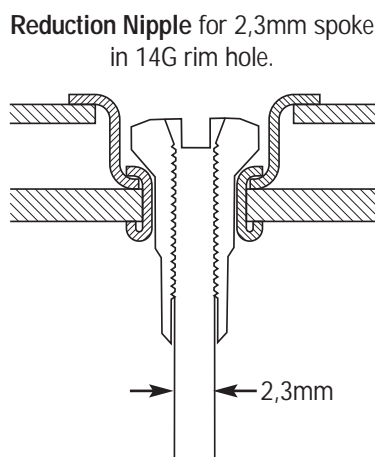

Reduction Nipple for 2,3mm spoke in 14G rim hole.

Reduction nipple for 2,3mm 13G spoke and 14G 4,5 mm rim hole.

## Aluminium Nipple



Silver colour alloy: 12,14,16 mm  
 Option: black, red, blue, gold, green, purple.  
 Aluminium nipples in EN 7075 are as strong as brass nipples.

Straight Spokes



Straight pull spokes are available for special hubs.

Black Spokes



All spokes are available in black except zinc

## SAPIM RACE TOOLS

Special Tools for proper wheel assembly



1. Nipple Clamping Screwdriver



2. Nipple Driver



3. Nipple Wrench



4. Special Nipple Key



5. Hexagonal Nipple Key

































6. Spoke Washers



7. Nipple Washers

Sapim Fatigue Test

Weight (64 pcs x 260 mm lg)		Wheel Revolutions (in cycles) Fatigue test																																											
<b>CX-Ray</b>	 278g	<table border="1"> <tr> <td>500.000</td> <td>1.000.000</td> <td>1.500.000</td> <td rowspan="7">+ 3.500.000</td> </tr> <tr> <td><b>CX-Ray</b></td> <td></td> <td></td> </tr> <tr> <td><b>Force</b></td> <td></td> <td></td> </tr> <tr> <td><b>Strong</b></td> <td></td> <td></td> </tr> <tr> <td><b>Laser</b></td> <td></td> <td></td> </tr> <tr> <td><b>Race</b></td> <td></td> <td></td> </tr> <tr> <td><b>Leader 14</b></td> <td></td> <td></td> </tr> <tr> <td><b>Zinc</b></td> <td> 424g</td> <td></td> <td></td> <td></td> </tr> <tr> <td><b>Leader 14</b></td> <td> 424g</td> <td></td> <td></td> <td></td> </tr> <tr> <td><b>Strong</b></td> <td> 430g</td> <td></td> <td></td> <td></td> </tr> <tr> <td></td> <td></td> <td><b>Zinc</b></td> <td></td> <td></td> <td></td> </tr> </table>	500.000	1.000.000	1.500.000	+ 3.500.000	<b>CX-Ray</b>			<b>Force</b>			<b>Strong</b>			<b>Laser</b>			<b>Race</b>			<b>Leader 14</b>			<b>Zinc</b>	 424g				<b>Leader 14</b>	 424g				<b>Strong</b>	 430g						<b>Zinc</b>			
500.000	1.000.000		1.500.000	+ 3.500.000																																									
<b>CX-Ray</b>																																													
<b>Force</b>																																													
<b>Strong</b>																																													
<b>Laser</b>																																													
<b>Race</b>																																													
<b>Leader 14</b>																																													
<b>Zinc</b>	 424g																																												
<b>Leader 14</b>	 424g																																												
<b>Strong</b>	 430g																																												
		<b>Zinc</b>																																											

Disclaimer: Sapim products are meant only for use by professional wheel builders. The terms of any contractual agreement and related guarantees are valid only if Sapim spokes and nipples are used together exclusively.

Other wheel components must first be approved by Sapim and assembled according to the latest assembly instructions issued by Sapim. Copies of these instructions are available from Sapim upon request.



"I TRUST ONLY THE BEST! THAT'S WHY I RIDE WITH SAPIM"  
*Kenny Belaey, 8 x World Champion Biketrial and 2 times World Cup Winner Trial*



"All Sapim spokes meet our stringent quality standards!"

**SAPIM** **SPOKES AND NIPPLES**

Terbekehofdreef 65  
 2610 Wilrijk (Antwerp)  
 Belgium

Tel.: +32 (0)3 740.08.20  
 Fax: +32 (0)3 828.81.39  
 info@sapim.eu

For our list of distributors see:

[WWW.SAPIM.EU](http://WWW.SAPIM.EU)